

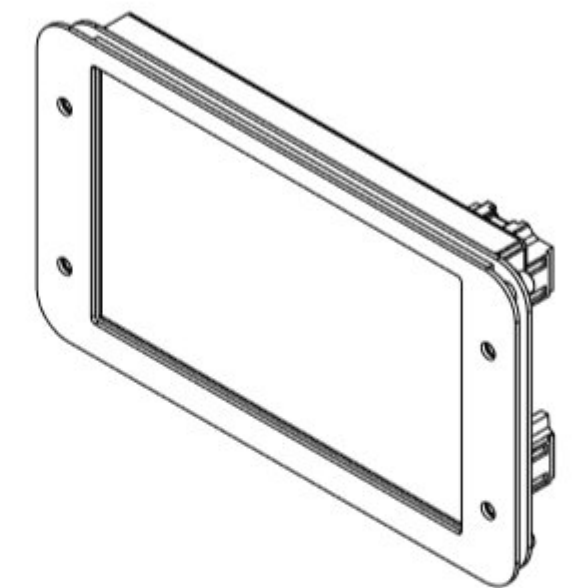

This Drawing and Subject Matter Discussed Herein Are Proprietary Items to Which SOC Retains the Exclusive Right of Dissemination, Reproduction, Manufacture, Use and Sale. This Drawing is Submitted in Confidence for Consideration by the Recipient Alone Unless Permission for Further Disclosure is Expressly Granted in Writing by SOC.

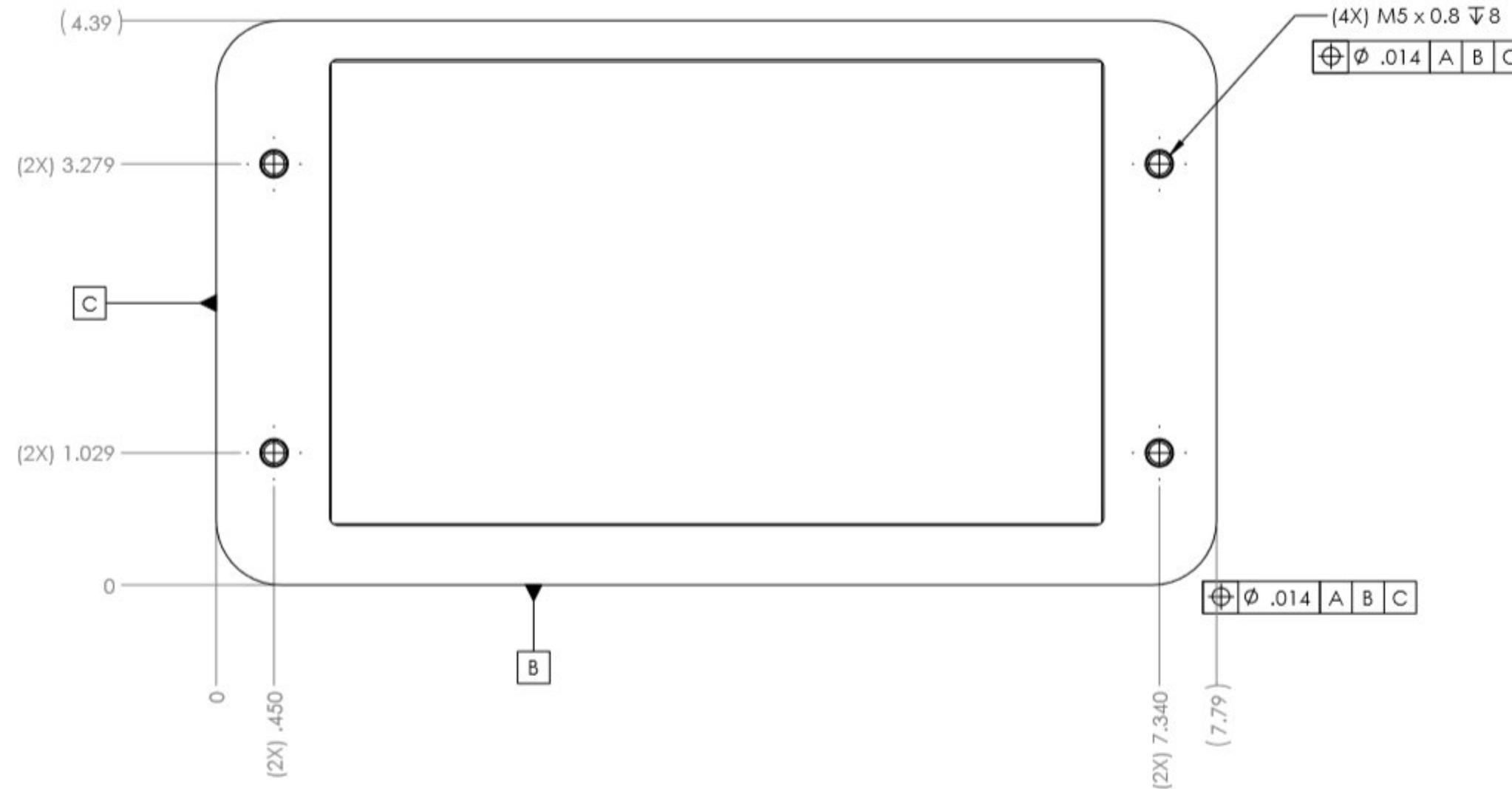
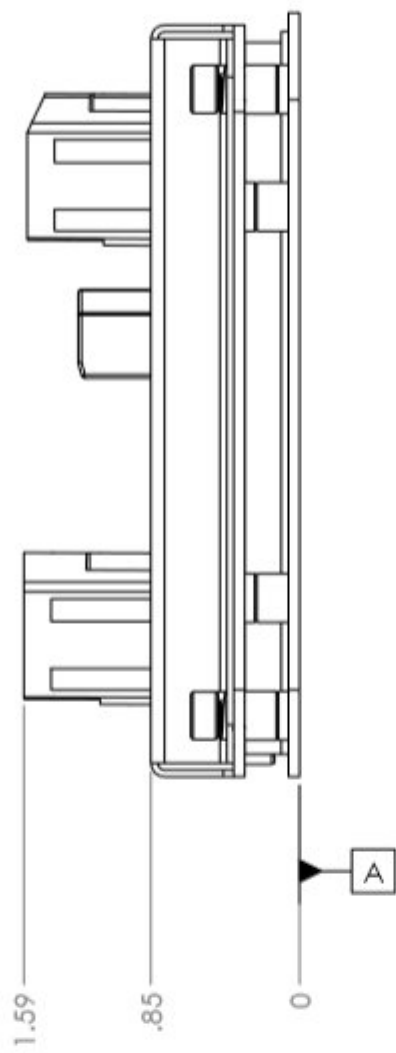
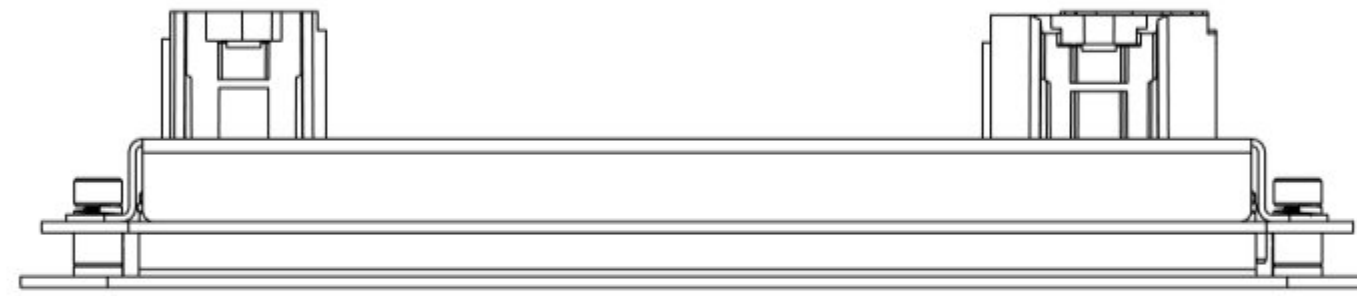

MATERIAL:		 ANDROMEDA INTERFACES 3402 Piazza De Oro Ste 100 Oceanside, CA 92056 TEL: (877) 332-6055 WWW.ai-hmi.COM	
FINISH:			
GENERAL INSTRUCTIONS: DIM AND TOL PER ANSI Y-14.5 BREAK AND DEBURR ALL SHARP EDGES DO NOT ANODIZE UNLESS INSTRUCTED TO DO SO CONTACT SOC CONCERNING MISSING DIMENSIONS ALL DIMENSIONS APPLY AFTER PLATING		UNLESS SPECIFIED DIMENSIONS ARE INCHES & MINIMUM TOLERANCES ARE: .X ± 0.1 .XX ± 0.01 .XXX ± 0.005 .XXXX ± 0.0005 FRACTIONS ± 1/64 ANGLES ± 30' SURFACE FINISH 64 --DO NOT SCALE DRAWING--	SOLIDWORKS GENERATED DWG ECO MODIFICATIONS MUST BE SIGNED, DATED, & IN PEN APPROVALS _____ DATE _____ DRAWN: k.coelho CHECKED: _____
SIZE: C	DWG. NO.:	SCALE: FILE:	REV. SHEET 1 of 1

EVIC